

No. 661,619.

Patented Nov. 13, 1900.

V. POULSEN.

METHOD OF RECORDING AND REPRODUCING SOUNDS OR SIGNALS.

(Application filed July 8, 1899.)

(No Model.)

3 Sheets—Sheet 1.

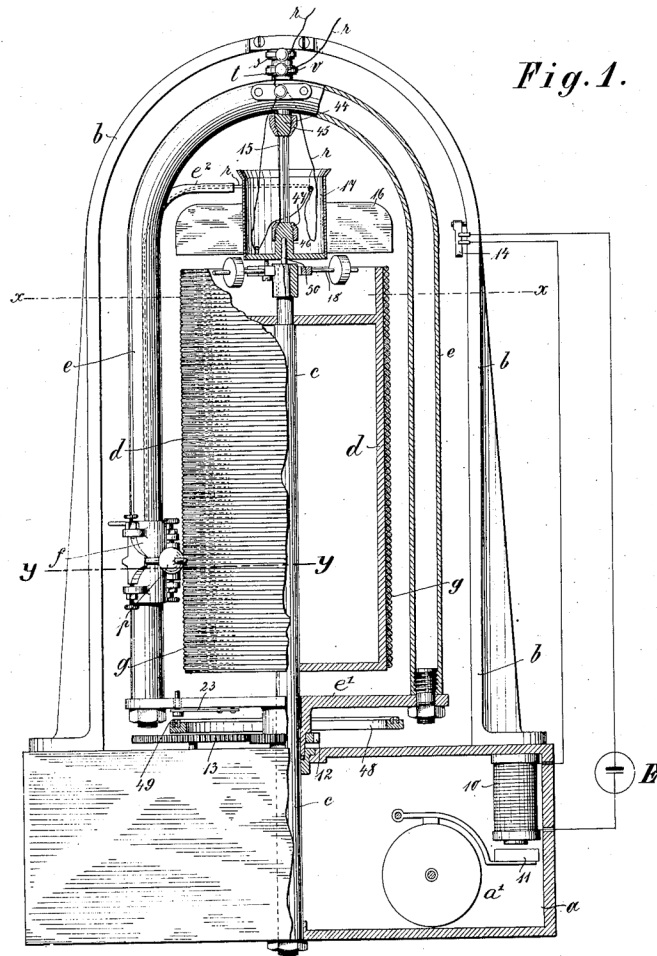

Fig. 1.

Witnesses:  
Frank J. Ober  
Waldo M. Chapin

Inventor:  
Valdemar Poulsen,  
by Wm. A. Reubens  
Att'y.

No. 661,619.

Patented Nov. 13, 1900.

V. POULSEN.

METHOD OF RECORDING AND REPRODUCING SOUNDS OR SIGNALS.

(Application filed July 8, 1899.)

(No Model.)

3 Sheets—Sheet 2.

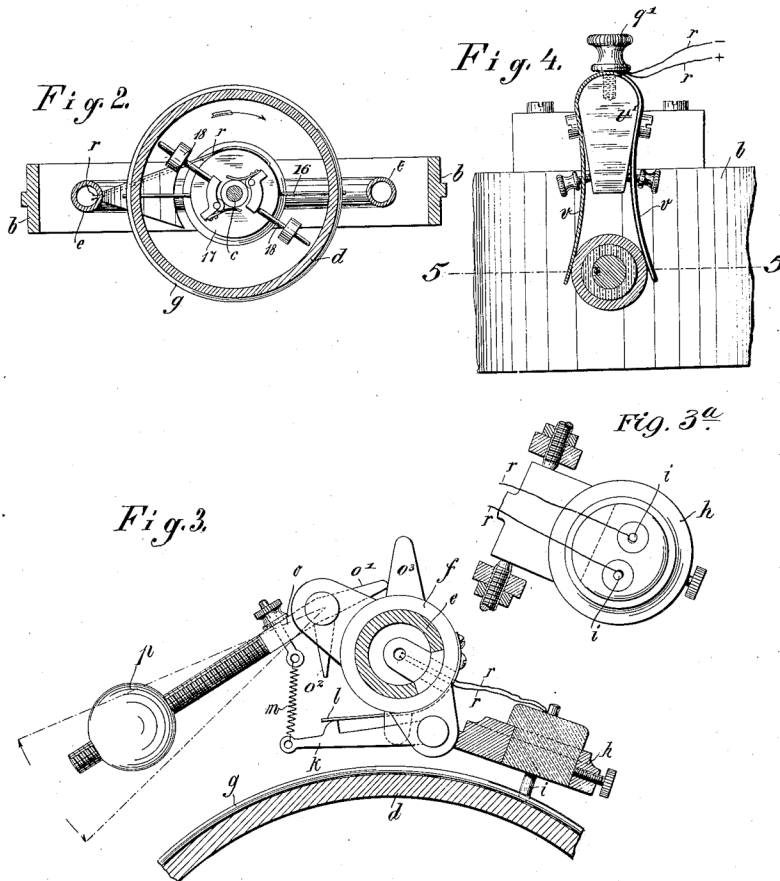

Witnesses:

Frank D. Ober  
Waldo M. Chapin

Inventor:  
Valdeimar Poulsen.

by *Wm. A. ...*  
Att'y.

No. 661,619.

Patented Nov. 13, 1900.

V. POULSEN.

METHOD OF RECORDING AND REPRODUCING SOUNDS OR SIGNALS.

(Application filed July 8, 1899.)

(No Model.)

3 Sheets—Sheet 3.

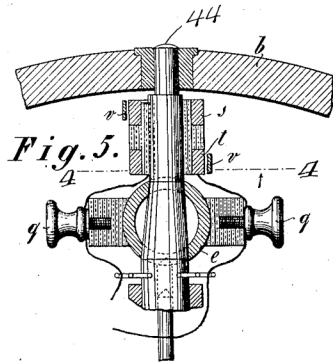
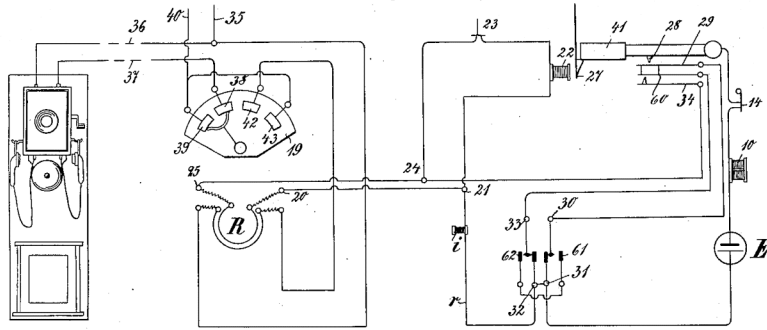

Fig. 6.



Witnesses:  
Frank S. Ober  
Waldo M. Chapin

Inventor:  
Valdemar Poulsen  
by *Wm. A. Reussman*  
Att'y

BEST AVAILABLE COPY

# UNITED STATES PATENT OFFICE.

VALDEMAR POULSEN, OF COPENHAGEN, DENMARK.

METHOD OF RECORDING AND REPRODUCING SOUNDS OR SIGNALS.

SPECIFICATION forming part of Letters Patent No. 661,619, dated November 13, 1900.

Application filed July 8, 1899. Serial No. 723,198. (No specimens.)

To all whom it may concern:

Be it known that I, VALDEMAR POULSEN, a subject of the King of Denmark, residing at Copenhagen, in the Kingdom of Denmark, have invented certain new and useful Improvements in Methods of and Apparatus for Effecting the Storing up of Speech or Signals by Magnetically Influencing Magnetizable Bodies, (for which I have applied for patents in England, No. 8,961, dated April 28, 1899; in Germany, dated December 9, 1898; in Austria, dated April 22, 1899; in Hungary, No. 6,494, dated May 1, 1899; in France, No. 276,184, dated April 26, 1899; in Belgium, No. 111,719, dated April 26, 1899; in Italy, dated May 2, 1899; in Spain, dated April 26, 1899; in Portugal, dated May 8, 1899; in Switzerland, No. 21,005, dated April 25, 1899; in Russia, dated April 26, 1899; in Norway, No. 11,076, dated April 26, 1899; in Sweden, dated March 20, 1899, and in Denmark, No. 1,260, dated December 1, 1898,) of which the following is a specification.

It has long been possible to transmit messages, signals, &c., by electrical means.

The present invention represents a very essential advance in this branch of science, as it provides for receiving and temporarily storing messages and the like by magnetically exciting paramagnetic bodies. The solution of this problem is based on the discovery that a paramagnetic body, such as a steel wire or ribbon, which is moved past an electromagnet connected with an electric or magnetic transmitter, such as a telephone, is magnetically excited along its length in exact correspondence with the signals, messages, or speech delivered to the transmitter, and, further, that when the magnetically-excited wire is again moved past the electromagnet it will reproduce the said signals, messages, or speech in a telephone-receiver connected with the said electromagnet.

The invention is of great importance for telephonic purposes, as by providing a suitable apparatus in combination with a telephone communications can be received by the apparatus when the subscriber is absent, whereas upon his return he can cause the communications to be repeated by the apparatus.

Further, the present invention will replace

the phonographs hitherto used and provide simpler and better-acting apparatus.

As is well known, in the usual phonographs the vibrations of air transmitted to a membrane are caused by means of suitable mechanical parts to make indentations in a receptive body, which indentations can cause a membrane to repeat the said vibrations by suitable mechanical means. Mechanical alterations of such bodies, however, give rise to disturbing noises, which apart from the expense of such apparatus is one of the principal reasons why the phonograph has not come more extensively into use.

In the accompanying drawings one form of this invention is illustrated.

Figure 1 is a front elevation and partial section of the phonographic apparatus. Fig. 2 is a section on line  $xx$  of Fig. 1 looking up. Fig. 3 is a section on line  $yy$  of Fig. 1 looking down. Fig. 3<sup>a</sup> is a detail view of the electromagnet and its carrier. Fig. 4 is a section on line 4 4 of Fig. 5. Fig. 5 is a section on line 5 5 of Fig. 4. Fig. 6 is a diagrammatic representation of electrical connections designed for the purpose of explaining the mode of operation of the invention.

In the apparatus illustrated the paramagnetic body used consists of a steel wire which is spirally wound on a drum.

The construction of the apparatus is as follows:

$a$  indicates a casing for a clockwork, one of the wheels of which is indicated by  $a'$ . Upon this casing is supported a stirrup-shaped frame  $b$ , the two arms of which are arranged on opposite sides of a central spindle  $c$ . On this spindle is mounted a cylinder  $d$ , which is held stationary by being fastened to the spindle in any suitable way, and the spindle itself is fixed to the casing.

$e$  is a bow-shaped frame consisting of a piece of tubing bent into shape and having its ends connected by an arm  $e'$ , mounted to turn on the spindle  $c$ . The upper end of the bow has a bearing at the middle of the frame  $b$  by means of a short stud 44, which passes through the bow and enters the frame  $b$ . Rotary motion is imparted to the bow  $e$  by means of the clockwork in the casing  $a$ , which is provided with a wheel 13, engaging with a pinion 12 on the hub of the arm  $e'$ . A fixed ring 48, car-

rying two annular electrical contacts 49 on its upper surface is arranged immediately below the arm *e'*, and said arm is provided with a spring-mounted pin 23, adapted to be forced into connection with both of said electrical contacts for the purpose of electrically connecting them together.

Upon the surface of the cylinder *d* is wound a steel wire *g* in a uniform helix. On one of the arms of the bow *e* is placed a sleeve *f*, adapted to slide freely up and down on the bow, it being held in a fixed relation thereto by means of a tongue-and-groove connection or in any other suitable manner. This sleeve has pivoted to it a magnet-holder *h*, the poles of the magnet therein being indicated by *i*. The magnet-holder is provided with a tail-piece *k*, which is normally pressed upon by a spring *l*, tending to force the poles of the magnet out of contact with the wire *g*.

*p* represents a weight adjustably fixed on an arm *o*, pivoted to the sleeve *f*. The arm *o* is connected with the tail *k* by a spring *m*. Centrifugal force acting upon the weight *p* tends to throw the magnet-holder toward the cylinder *d*, and thus bring the poles of the magnet into contact with the wire *g*, in which operation the spring *l* is compressed, so that when the centrifugal force ceases said spring will act upon the tail-piece *k* to remove the poles of the magnet from the wire *g*. The arm *o* has two extensions *o'* and *o''*, which serve as stops to limit the movement of the weight *p* in both directions. The sleeve is also provided with a finger *o''*, the purpose of which will be explained hereinafter. With reference to the magnet *i* it may be stated that it may have one or two of its pole-pieces arranged to engage the wire *g*. If a single pole-piece is used, the end thereof will be rounded or made wedge-shaped to fit between two adjacent convolutions of the wire and in contact with both of them, while if the two pole-pieces are used, as is shown in the drawings, they may make contact with opposite sides of a single convolution of the wire, the poles being pointed for this purpose, or they may slide in the adjacent grooves between the wires and straddling one convolution.

The two wires *r*, in which the magnet *i* is connected, lead from the magnet through the open slot in the bow *e*, thence upward through said hollow bow to a point near the upper end thereof, where they pass out through a flaring nozzle *e''*, thence around the outside of a drum 17, through a hole in the side thereof, and thence upward to a pair of binding-screws *q*, arranged on the opposite sides of the bow *e* at its middle point, the wires being slack between said binding-screws and the opening in the drum. From said binding-screws the wires lead on, respectively, to two insulated rings *s* and *t* on the short stud 44. Upon each of these rings a contact-spring *v*, attached to a block *v'*, rests, and to these springs the main wires are respectively connected by means of the binding-screws *q*. The said drum 17 is

mounted freely on the upper end of the spindle *c*, and on its under side it has pivoted to it two weighted levers 18, each of which carries a spring forming a brake-shoe resting upon the surface of the fixed spindle *c*. These weighted levers are so arranged that centrifugal force will increase the pressure of the brake-shoes upon the spindle, and so retard the rotary motion of the drum 17. The drum also carries a pair of wings 16, which have a retarding effect upon the rotary motion of the drum. The drum is connected with the bow *e* by a flexible or yielding connection consisting of a number of wires 15, which are clamped to the drum by a conical nut 47, engaging with the hub 46 and with the bow by a similar nut 45, engaging with the end of the stud 44. It will now be seen that when the bow rotates it will carry the drum 17 with it; but owing to the action of the brake 18 and the wings 16 there will be a certain amount of lagging on the part of the drum which will be permitted by the twisting of the wires 15.

The clockwork is normally prevented from rotating by the weight of the armature 11, which acts upon the brake, as shown in Fig. 1. The brake is released by the electromagnet 10 in a circuit with battery *E* and a cut-out 14, attached to the frame *b*.

The apparatus so far described is a phonograph, the operation of which may be now referred to.

Let it be assumed that speech or signals are being electrically transmitted over the circuit containing the magnet *i*, that the sleeve *f* is at the lower end of the bow, and that the machine is started by closing the circuit of magnet 10. The bow *e* immediately commences to rotate around the cylinder *d*. When the speed is sufficient, centrifugal force acting upon the weight *p* will cause the core of the magnet *i* to be thrown into contact with the wire *g*, whereupon the sleeve will be caused to slide upward upon the bow owing to the spiral arrangement of the wire on the cylinder. At the same time the undulations of current in the circuit of magnet *i* will vary the magnetism of said magnet, which variations will be successively imparted to the wire *g*. The message may continue until the sleeve *f* reaches the elevation of the cut-out 14, whereupon the finger *o''* on the sleeve strikes said cut-out and opens the circuit of magnet 10. Armature 11 then falls and stops the clockwork, whereupon spring *l* withdraws the poles of the magnet *i* from wire *g* and the sleeve falls by gravity to its lower position. The brake 18 is adjustable, so that the lagging of the drum 17 behind the bow *e* will be just sufficient to wind the wires *r* upon the drum as the slack in said wires is created by the upward movement of the sleeve *f*. To reproduce the message which has thus been magnetically recorded, it is only necessary to put a receiving-telephone into circuit with magnet *i* instead of the transmitting-telephone and then start the machine again,

whereupon the sleeve will travel up on the bow and the poles of the magnet will traverse the wire *g*, the successively-varying magnetic condition of which will react upon the core of the magnet and cause the same undulations of current to be sent over the line to the receiving-telephone as were previously sent over the line to the magnet from the transmitting-telephone.

The connection of the apparatus to a telephone is shown in Fig. 6. A switch 19 is provided having four terminals 38, 39, 42, and 43. These terminals can be connected with each other in three different ways by means of the switch-lever. In the position shown in the drawings the two terminals 38 and 39 are connected together. This position establishes the circuit for the ordinary use of the telephone. The current passes through the conductor 35 and the conductor 36 to the telephone and through the conductor 37 and terminals 38 and 39 back to the conductor 40. The two conductors 35 40 constitute the outgoing and return lines. If the switch-lever is so adjusted as to connect the two terminals 38 and 42, the apparatus can then be used as a phonograph, and the transmitting-telephone belonging to the same station can then be used. To clearly explain this, the course of the current should be followed when the terminals 38 and 42 are connected. When the subscriber turns the crank-handle of his induction apparatus, a current will pass through the outer coil of the induction-coils R. The current issues from the telephone and passes over the conductor 36 to the outer coil of the induction-coils R, then through the terminals 42 to the terminal 38, and over the conductor 37 back to the telephone. A current is then induced in the inner coil of the induction-coils R, which will take the following course: It passes from the terminal 20 of the inner coil of the induction-coils R to the electromagnet 22, through the contact 23, conductor 24, and terminal 25 back to the inner coil of the induction-coils R. The electromagnet 22 is thus excited and the armature 27 attracted, whereupon a weighted block 41 is released and falls. By this means contact is made between the contact-piece 28 and spring 29, whereby the local circuit of the battery E is closed. The circuit is as follows: The current passes from the battery E through the electromagnet 10, contact 14, contact-piece 28, spring 29, terminals 30 31, and back to battery E. The electromagnet 10, Fig. 1, now attracts the armature 11, so that the clockwork is set in motion and the bow *e* rotated. The sleeve *f*, which has been resting upon the pin 23, begins to rise and the connection between the contacts 49 is broken. The contact 23 consequently exists only for an instant, so that the circuit of the conductors 20 21 22 23 24 25 is open during the operation of the clockwork and apparatus. Now during the rise of the sleeve *f* and while the electromagnet *i*, Fig. 3, is in contact with the

steel wire *g* in the manner described the subscriber can speak into his transmitter and the spirally-wound steel wire *g* will be correspondingly magnetically excited. The course of the current in this case is as follows: It passes from the telephone apparatus through the conductor 36, the outer coil of the induction-coils R, the terminals 42 38, and conductor 37 back to the transmitter. In exact correspondence with the matter spoken into the transmitter currents are induced in the inner induction-coil. Such currents issue from the terminals 20 21, pass through the electromagnet *i*, conductor *r*, terminals 32 33, contact-springs 60 34, and terminals 24 25 back to the inner induction-coil. The contact between 60 and 34 is also effected by the falling of block 41. The electromagnet *i* is magnetized in correspondence with the matter spoken and transfers its magnetism to the steel wire *g*. The matter thus fixed can now be transmitted over the line by using the third connection—that is, by connecting the terminals 42 and 43 of the switch 19.

If, for example, the message, "The subscriber is not at home at present, but will return at four o'clock, at which time please ring again," is fixed to the steel wire and a subscriber at some other station calls the former, when the contact-pieces 42 43 are connected together the following circuit will be described: The induced current from the transmitting-station will first pass over the conductor 35 to the outer coil of the induction-coils R and then through the terminals 42 43, whereupon it will pass through these to the line 40, because the terminal 43 is connected with the terminal 39. The line-current will accordingly not pass through the telephone of the receiving-station; but because the contact 23 is then closed the electromagnet 22 is again excited by the current generated in the inner coil of the induction-coils R and the drum *d* is rotated. The electromagnet *i* will slide along the fixed wire *g* and gradually rise with the sleeve *f* and will be magnetized in accordance with the speech fixed on the wire. The currents induced thereby pass from the electromagnet *i*, Fig. 7, through the terminals 33, contact-springs 60 and 34, terminals 24 25 to the inner coil of the induction-coils R, and then through the terminals 20 and 21 to the electromagnet *i*. In the inner coil of the induction-coils R a current is induced corresponding to the speech fixed to the steel wire, which current likewise acts in the outer coil of the induction-coils R and passes thence through the terminals 42 43 39 to the line conductor 40 and back over the conductor 35 into the outer coil of the induction-coils R. The subscriber at the transmitting-station now hears through his receiver the message fixed to the steel wire and knows that in order to speak with the subscriber at the receiving-station he must call him up at four o'clock.

In order to demagnetize the steel wire *g*,

Fig. 1, the terminals 30 and 33, Fig. 7, are connected with 61 and 62, whereupon the following connection is made: The current passes from battery E through the terminals 31 and 32 to the electromagnet *i*, through the terminals 21 20, inner coil of the induction-coils R, terminal 25, contact-springs 34 60, contacts 33 62 61 30, contact-spring 29, contacts 28 14, and electromagnet 10 back to the battery E. The electromagnet *i* is in this position of the switch uniformly magnetized by the battery E and demagnetizes thereby the steel wire *g* on the bow *e* rotating.

For telegraphic purposes the invention can also be used with advantage. It is in such case only necessary to receive the current impulses transmitted over the line in the electromagnet while it is in contact with the paramagnetic body. The paramagnetic body may be moved past the electromagnet, or vice versa.

Having described my invention, I claim—

1. The method of recording and reproducing speech or signals which consists in impressing upon an electric circuit containing an electromagnet, undulations of current corresponding to the sound-waves of speech or to the signals; simultaneously bringing successive portions of a magnetizable body under

the influence of said electromagnet and thereby establishing in said body successively-varying magnetic conditions; and finally subjecting an electromagnet connected in a circuit, successively to the various magnetic conditions established in said body, substantially as described.

2. The method of recording and reproducing speech, signals, &c., which consists in imparting magnetic conditions successively to a magnetizable body or surface, said conditions varying in accordance with the sound-waves produced by said speech or signals and then subjecting a reproducing apparatus to said magnetic conditions successively.

3. The method of storing up signals or messages represented by undulating or irregular currents, which consists in imparting to various portions of a magnetizable body, magnetic conditions corresponding to said undulating or irregular currents.

In testimony whereof I have hereunto signed my name in the presence of two witnesses.

VALDEMAR POULSEN.

Witnesses:

VALDEMAR CHRISTENSEN,  
NIELS CHRISTIAN BÖTCHER.